

WAGNERINOX

➔ 1000 WOG/PN 63 3-PIECE FULL PORT (3PC)



FEATURES

- The thread ends conform to
ASME B1.20.1(NPT)
DIN 2999 & BS 21
ISO 228/1 & ISO 7/1
- Investment casting
- Blow-out proof stem
- Full Port
- 1000 W.O.G./PN 63
- PTFE seal & packing
- Latch lock handle (option)
- Mounting pad Tapping(option)
- 1/4"-1"2000 W.O.G.(option)
- 1/4"-2"1500 W.O.G.(option)

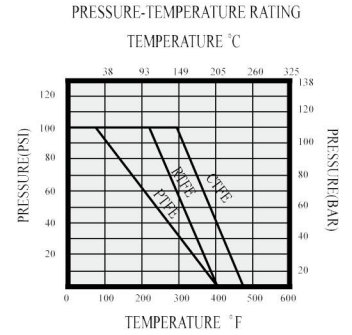

Applicable Standard	
Test and Inspection	API 598

ITEM	PARTS	MATERIAL	
1	BODY	ASTM A351-CF8M	ASTM A216-WCB
2	CAP	1.4408	1.0619
3	BALL	ASTM A351-CF8M/1.4408	
4	STEM	ASTM A276-316	
5	GLAND NUT	AISI 304	
6	BALL SEAT	PTFE/RTFE/CTFE	
7	BODY SEAL	PTFE	
8	PACKING		
9	THRUST WASHER	AISI 304	
10	SPRING WASHER		
11	STEM NUT		
12	BOLT		
13	BOLT NUT	PVC	
14	SPRING WASHER		
15	HANDLE	PVC	
16	HANDLE SLEEVE		

*RTFE=15% GLASS FIBER+TFE

*CTFE=25% CARBON+TFE

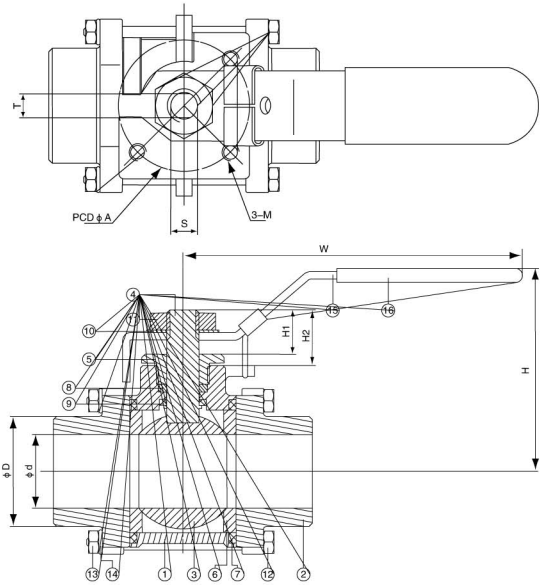

PN63	8	10	15	20	25	32	40	50	65	80	100
	11.5	12.7	15	20	25	32	38	50	65	80	100
	17.5	17.5	22	27	34	42.5	48.5	61	73	92	115
	64.5	65.5	66	83	95	111	131	151	186	212	235
	117	117	117	137	157	157	195	200	285	285	315
	57	57	57	60	80	85	95	110	135	148	170
	11	11	11	14	15.5	15.5	18	18	31	31	40
	15	15	15	19.5	23.5	20	26	26	40	38	53
	5	5	5	6.5	8	8	9	9	12	12	16
	5/16"UNF	5/16"UNF	5/16"UNF	3/8"UNF	7/16"UNF	7/16"UNF	9/16"UNF	9/16"UNF	3/4"UNF	3/4"UNF	1"UNF
	36	36	36	36	42	50	50	70	102	102	102
	M5	M5	M5	M5	M5	M6	M6	M8	M12	M12	M12

Unit:mm