

3-Way Ball Valve

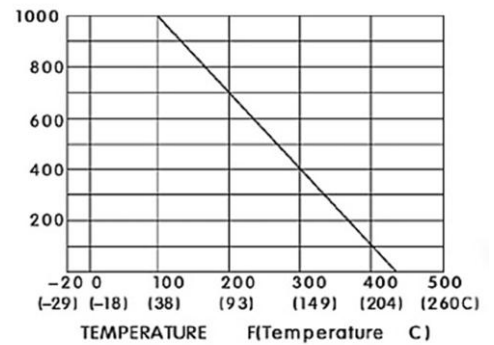

FEATURES

- ◆ Body & cap in ASTM-A351-CF8, ASTM-A351-CF8M
- ◆ Blow-out proof stem, lever operated
- ◆ 1000 PSI (69 BAR) W.O.G.
- ◆ Mounting Pad for ISO 5211
- ◆ L port, T port



TIEM	PARTS	MATERIAL	Q'TY
1	BODY	ASTM-A351-CF8M	1
2	END CAP	ASTM-A351-CF8M	2
3	BALL SEAT	PTFE	4
4	BALL	ASTM-A351-CF8M	1
5	STEM	AISI 316	1
6	END SEALS	PTFE	2
7	THRUST WASHER	PTFE	1
8	GLADN NUT	AISI 304	1
9	HANDLE	AISI 304	1
10	HANDLE WASHER	AISI 304	1
11	WASH	AISI 304	1
12	HANDLE NUT	AISI 304	1
13	PLASTIC COVER	PLASTIC	1
14	END CAP	ASTM-A351-CF8M	1
15	STEM PACKING	PTFE	2
16	END SEALS	PTFE	1
17	LOCK	AISI 304	1
18	STOP PIN	AISI 304	1

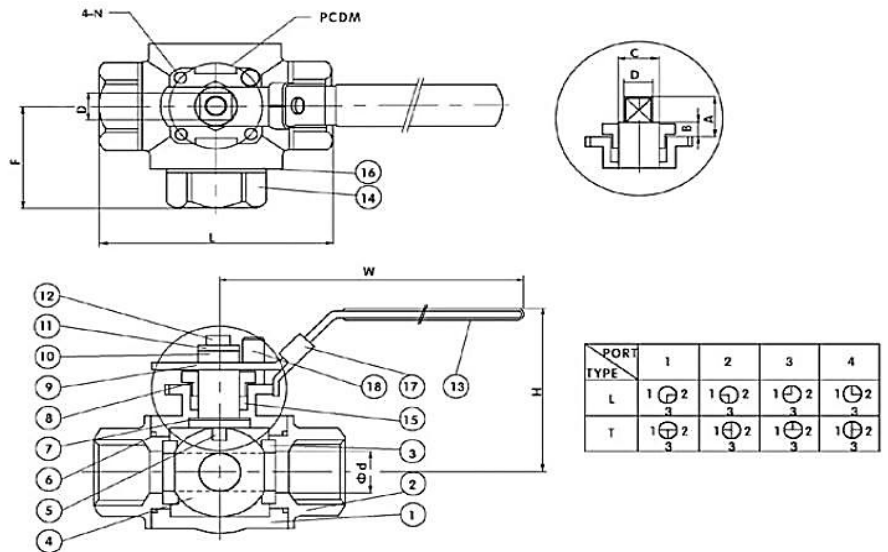

DIMENSIONS UNIT:mm

SIZE	Φd	L	B	D	C	A	F	W	H	M	N	Cv FACTOR	TORQUE Kgf-cm
1/4"	12.7	64	6.0	9.0	12.7	10.2	32	132	60	42	M5×0.8	68	7.8
3/8"	12.7	64	6.0	9.0	12.7	10.2	32	132	60	42	M5×0.8	68	7.8
1/2"	12.7	75	6.0	9.0	12.7	10.2	37.5	132	60	42	M5×0.8	68	9.5
3/4"	16.0	84	6.0	10.7	15.0	16.0	42	155	73	50	M6×1	105	14.0
1"	20.0	101	7.5	10.7	15.0	18.0	50.5	155	80	50	M6×1	196	26.0
1-1/4"	25.0	119	7.5	10.7	15.0	18.0	54.5	155	85	50	M6×1	266	43.0
1-1/2"	32.0	130	8.5	14.0	20.0	19.0	65	210	103	70	M8×1.25	363	70.0
2"	38.0	151	8.5	14.0	20.0	19.0	75.5	210	110	70	M8×1.25	500	102.0